

External  
Roller Blinds  
Sun Control





# External Roller Blinds

High quality solar shading  
Controlling temperature and light

## **DURABILITY, COMFORT AND QUALITY**

While attractive modern buildings with large glazed areas offer an important link with the outside world, they also impose greater demands on the thermal environment of the building. Offices, schools, hospitals and other non-residential buildings can all significantly improve the working conditions for their occupants by incorporating sophisticated solar shading systems from Hunter Douglas.

The professional made-to-measure external roller blinds from Hunter Douglas are designed to improve indoor environmental quality and conserve energy. These systems help to create comfortable, healthy and productive environments while lowering air conditioning energy consumption. The Hunter Douglas project support team can offer analysis, visuals and design optimisation for each individual project to ensure total confidence and peace of mind.

## **EASY AND COST EFFICIENT INSTALLATION**

The modular components exclusively developed by Hunter Douglas allow for easy installation, connection and operation of HunterDouglas® Roller Blinds. In addition these external blinds are suited to virtually any building, whether it is a new build or a refurbishment project. The versatile roller blinds can either be hidden or used as a feature to add the extra finishing touch to a building's façade.

HunterDouglas® External Roller Blinds have the advantage of thermal and visual comfort, competitively priced, long lifetime, low maintenance and operation costs and quick installation, resulting in a low Total Cost of Ownership (TCO).



Left : Sports & Recreation Park 'De Nekker'  
Location : Mechelen, Belgium  
Architect: VenhoevenCS architecture+urbanism / BURO II & ARCHI+I

<u>CONTENTS</u>	<u>Page</u>
Advantages	
External Roller Blinds	2 - 3
Glass Fibre Fabrics	4
Assortment	5
Standard equipment	6 - 7
ProScreen	8 - 9
ProScreen Zip	10
Ultimate Screen Zip	11

#### FACTS AND FIGURES

- Internal heat gain reduction up to 90%.
- Internal light level reduction up to 97%.
- Optimum external through vision
- Privacy maintained from within
- Wind load resistance up to 27 m/s  
(TÜV tested in accordance with NEN-EN 13561).
- Meets product standard NEN-EN 13561.

Designed to work for you



**HunterDouglas**   
Window Coverings

# Advantages External Roller Blinds

## MINIMISE THE BOUNDARY BETWEEN INSIDE AND OUTSIDE

Given a choice most people would prefer to be outside, it can be easier to relax and the feeling of freedom often leads to increased productivity and creativity. By installing glass, the contact between the living and working environment and the outside world can be enhanced. The disadvantage of glass is that, of course, daylight and the sun's rays shine in, which cause glare and increased thermal gain. Hunter Douglas® external sun protection systems offer the perfect solution for making the environment as comfortable and sustainable as possible.



Above: Warsaw Business Garden office buildings - Location: Warsaw, Poland - Architect: JSK

## HIGH QUALITY GLASS FIBRE FABRIC

It is possible to create an optimal internal environment with the Hunter Douglas® range of external roller blinds due to the high quality glass fibre fabric. The open weave of the glass fibre fabric reduces heat gain internally by 90% and light level up to 97%, while allowing diffused light to pass through. The even distribution of the light that passes through the fabric ensures optimal contrast in the field of view and prevents glare. This is soothing to the eyes and makes working with digital screens and displays very comfortable.



Glare effect on the laptop screen



Minimised glare effect on the laptop screen

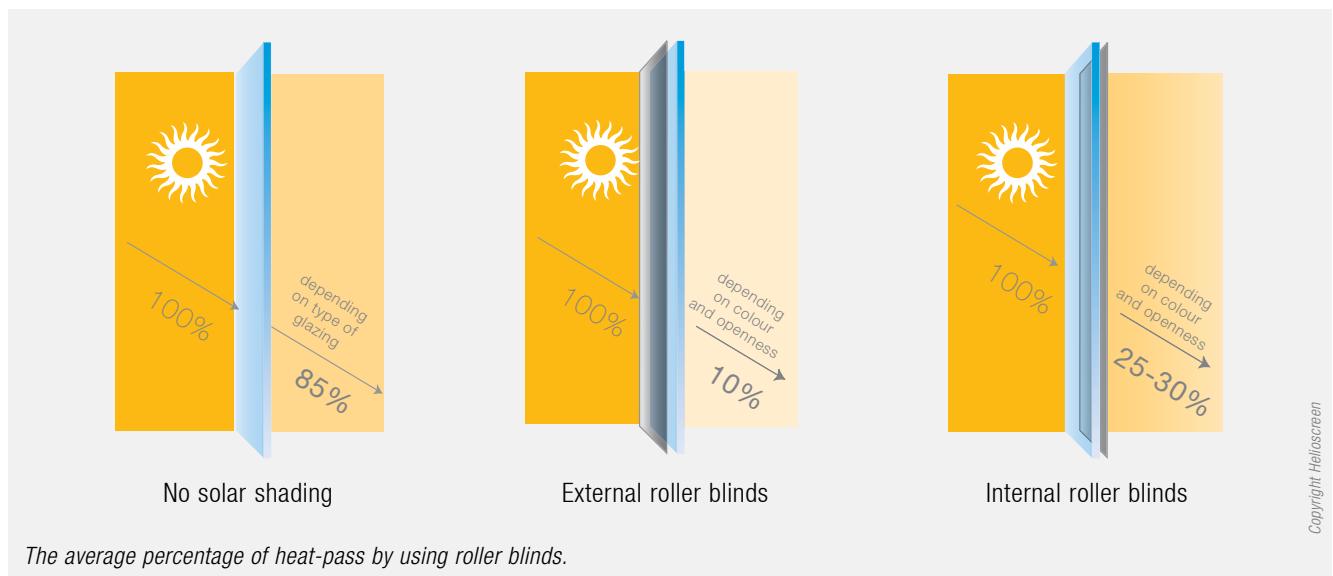

Copyright Helioscreen



# Advantages External Roller Blinds

## REDUCTION IN THE TOTAL COST OF OWNERSHIP (TCO)

During building and renovation projects there are always situations that turn out differently than what was expected. This causes undesirable extra costs, so having a clear insight in the overall investment in advance is always attractive.

HunterDouglas® External Roller Blinds have been developed as a result of this experience. Hunter Douglas always offers a suitable roller blind for any building. Due to the long lifetime, low installation, maintenance and operation costs, expenditure is transparent in the long term and carry low overheads across the total ownership life. That contributes to a lower 'Total Cost of Ownership' or TCO.

## SUITABLE FOR ANY BUILDING

The stable and robust HunterDouglas® range of External Roller Blinds are constructed from high quality parts. These parts contribute to a well-designed façade:

- Stainless steel side cables or sleek aluminum side channels with an appropriate headbox (natural anodized or powder coated).
- High-performance HunterDouglas® glass fibre fabrics.

Using discreet stainless steel side cables or sleek aluminium side channels with an appropriate headbox, natural anodized or powder coated, and high-performance HunterDouglas® glass fibre fabrics contribute to a well-designed façade. A number of designs have been developed for each component, so that we can offer the right solution for virtually any building.



Above: Warsaw Business Garden office buildings - Location: Warsaw, Poland - Architect: JSK



Above: Sandakerveien 114 - Location: Oslo, Norway



Above: Hôtel de ville - Location: Belgium - Architect : KAWAS Arkitekter

# Glass Fibre Fabrics

HunterDouglas® glass fibre fabrics are a proprietary combination of superior-quality glass yarns and coatings, fully tested production techniques, with proven performance characteristics. These fabrics with glass core technology:

- ensure outstanding strength, colour fastness, durability, performance and transparency for outdoor and indoor shade applications, including even the largest shades.
- have been tested for the highest levels of performance, with a wide fabric collection.
- provide excellent protection against UV radiation, resistant to water damage, rot, heat and remain dimensionally stable to prevent sagging and stretching.

The solar shading fabrics are highly efficient against solar heat gain, contributing to sustainable buildings by effectively managing solar heat, diffusing incoming natural light, enhancing interior comfort and increasing occupant productivity.

Depending on the product size, fabrics can be executed with a welded joint.

## SERGÉ

The HunterDouglas® glass fibre fabric Sergé is made from Tex 165 glass fibre with a PVC coating. The fabric forms a diagonal pattern, which looks different from the front and the back. This fabric is available in 10 colours in a range of widths from



1.60 m as standard up to a width of 3.20 m (available in black and grey shades only).

The openness factor of the fabric is 3%. The fire resistance of the Sergé fabric meets:

- M1 (according to French standard NF P92-503)
- B1 (according to German standard DIN 4102)
- C-S3,d0 (according to the European standard NEN-EN 13501-1).

## CARRÉ

The HunterDouglas® glass fibre fabric Carré is, just like Serge, made from Tex 165 glass fibre with a PVC coating. The plain weave forms a check pattern which looks the same from the front and the back. This fabric is available in 11 colours to a standard width of 2.50 m. The openness factor of the fabric is 5%.



The fire resistance of the Carré fabric meets:

- M1 (according to French standard NF P92-503)
- B1 (according to German standard DIN 4102)
- C-S3,d0 (according to the European standard NEN-EN 13501-1).

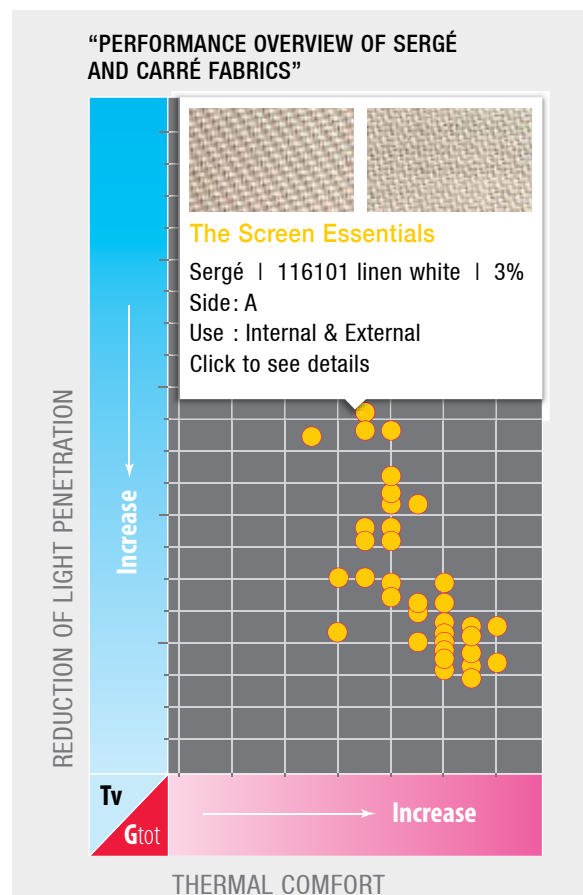

*For professional advice, technical analysis and the best type of fabric and colour to choose on your next project, please contact your nearest Hunter Douglas office.*

# Assortment

## EXTERNAL ROLLER BLINDS

Hunter Douglas offers a professional assortment of External Roller Blinds with a long lifecycle.



### PROSCREEN

ProScreen is a standard roller blind that is suitable for every building.

Features of ProScreen are:

- Windload resistance up to 12 m/s\*
- Available in a square and chamfered headbox (75, 85 en 95)
- Applicable on face, on the frame, in or behind the façade or in recess
- Max. 3500 x 4000 mm
- Linkable system
- Standard side guiding 27 x 20 mm secured end stop included
- Various bottom rails available including extra noise reduction
- Motorised or manually operated
- Quick installation close to the façade
- Quick access to the hardware via the service lid
- Economical solution
- Virtually maintenance-free.



### PROSCREEN ZIP

ProScreen Zip is a fully closed roller blind with a high wind load resistance, incorporating small sized headboxes.

Features of ProScreen Zip are:

- Windload resistance up to 27 m/s
- Available in a square and chamfered headbox (85 en 95)
- Applicable on the façade and in recess
- Max. 3000 x 3000 mm
- Standard side guiding 38 x 27.5 mm with secured end stop included
- Bottom rail 20 x 38 mm
- Motorised operation
- Quick installation close to the façade
- Economical solution.



### ULTIMATE SCREEN ZIP

Ultimate Screen Zip is a fully closed roller blind with a high wind load resistance and a patented click fixation.

Features of Ultimate Screen Zip are:

- Windload resistance up to 27 m/s
- Available in a square and chamfered headbox (100 x 125)
- Applicable on the façade
- Max. 3000 x 5000 mm/4300 x 3400 mm
- Standard profile 37.5 x 38 mm
- Bottom rail 22 x 48 mm
- Motorised operation
- Quick click installation on the head box to the prefixed side guiding.
- Easy access to the hardware and maintenance friendly
- Perfectly applicable for high small windows.

\* cable guiding excluded

# Standard equipment

## STANDARD AND CONTRA ROLLING

In line with building design, glass fibre fabric can be rolled out from the HunterDouglas® External Roller Blinds head boxes in two ways, namely:

- Standard rolling (back rolling)
- Contra rolling (front rolling)\*.

\* Only available in the square profile ProScreen head boxes.

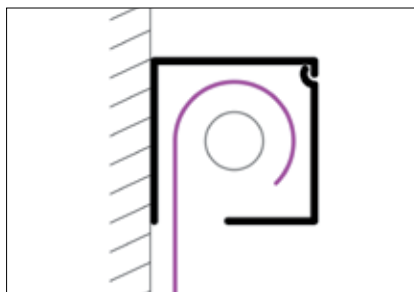

Standard rolling

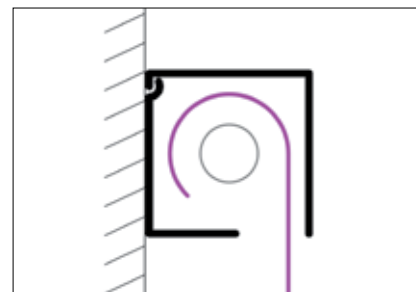

Contra rolling\*

## FINISH ON REQUEST

The base material of the HunterDouglas® range of External Roller Blinds is extruded aluminium with a natural anodised finish or powder coated in any RAL colour.

The Roller Blinds are fitted with an end cap at both ends, made from cast zinc (in ProScreen and ProScreen Zip) or aluminium alloy (in Ultimate Screen Zip). End caps are coated RAL 9022 and are combined with a natural anodised head box.

## APPLICATION

HunterDouglas® External Roller blinds can be used as a built-on, recess system (depending on the measurements of the recess or niche), or as a built-in system.



On the frame installation

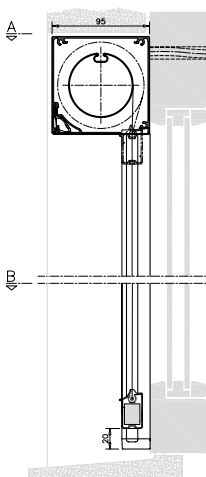

On face or on the frame installation. Possible for all squared and chamfered head boxes.

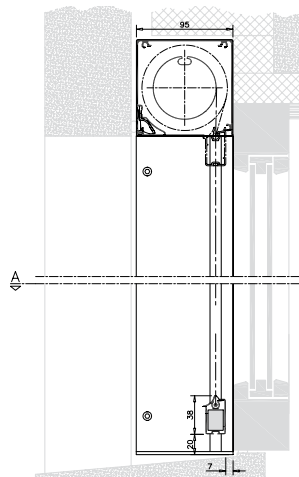

Installation in/behind the façade. Possible for type 95 without a head box.

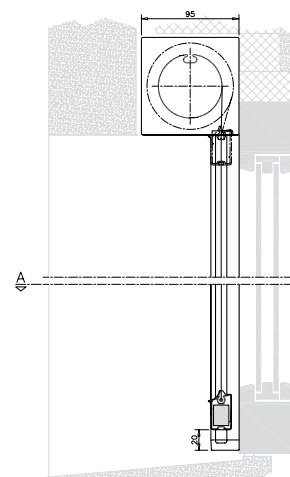

Installation with recess in the façade. Possible for type 95 with or without a head box.



Recess installation

Type	On face or on the frame installation	Installation in/behind the façade	Installation with recess in the façade
ProScreen	X	X	X
ProScreen Zip	X		X
Ultimate Screen Zip	X		



# Standard equipment

A recess guide system is mounted on the outer wall sealing it fully. Applicable in type 95.

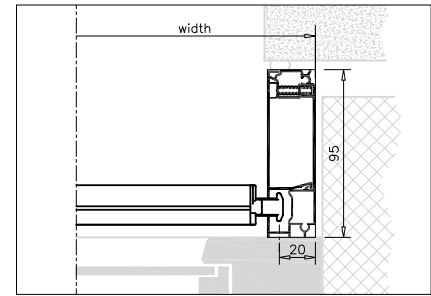

*Recess*

## CONTROL

HunterDouglas® Roller blinds can be operated in a variety of ways:

1. Motorised control by a 230V motor, compatible with a wide range of intelligent electrical installation and building system technologies that include switches, sun and wind sensors and building management systems.
2. Manual control with a crank handle mechanism.

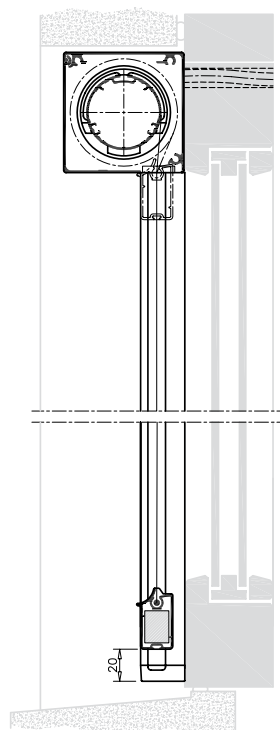

*Motorised control*

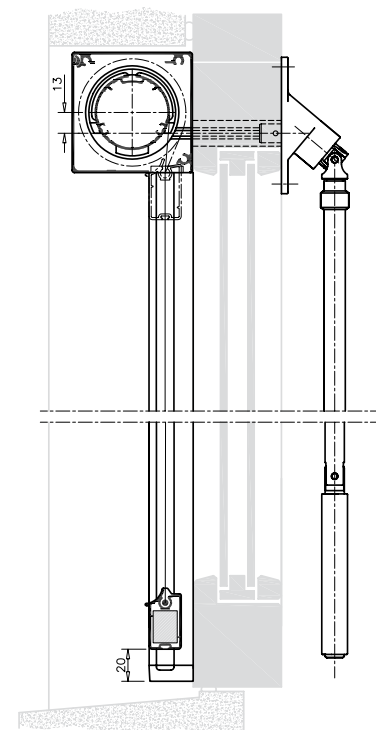

*Manual control*

Head box type	Headboxtype	75	85	95	100	125
Proscreen	Manual	X	X	X		
	Motorised	X	X	X		
ProScreen Zip	Motorised		X	X		
Ultimate Screen Zip	Motorised				X	X

# ProScreen

## SYSTEMS

HunterDouglas® ProScreen is made up of three systems, in a range of designs suitable for virtually any building. The selection depends on the dimensions of the window and the desired design.

Type	Square	Chamfered	Without
75	x	x	
85	x	x	
95	x		x



*Square head box*



*Chamfered head box*



*Without a head box*

Type	Cable guiding Max. width x height in mm	Aluminium guiding Max width x height in mm
75	2600 x 2900	2600 x 2900
85	2600 x 3000	2600 x 3400
95	-	3500 x 4000

## COUPLING SYSTEMS

HunterDouglas® ProScreen offers the ability to couple two or three lateral guide systems together and to operate them with a motor. This coupling can be enclosed in a continuous head box (75 and 85), or separate head boxes can be linked to each other laterally (75, 85 and 95).

Where the ProScreen head boxes are coupled there is a gap of at most a few millimetres between the individual screens.



*Coupling with continuous head box and separate head boxes*



# ProScreen

## GUIDE SYSTEMS

HunterDouglas® ProScreen provides six possible guide systems using two technologies:

1. Stainless steel cable guide
2. Extruded aluminium lateral guides.

The extruded aluminium lateral guide profiles are fitted underneath with a black end cap, with the exception of the "Recess" profile.

*Each type of guide system has been developed for a specific application or mounting method.*

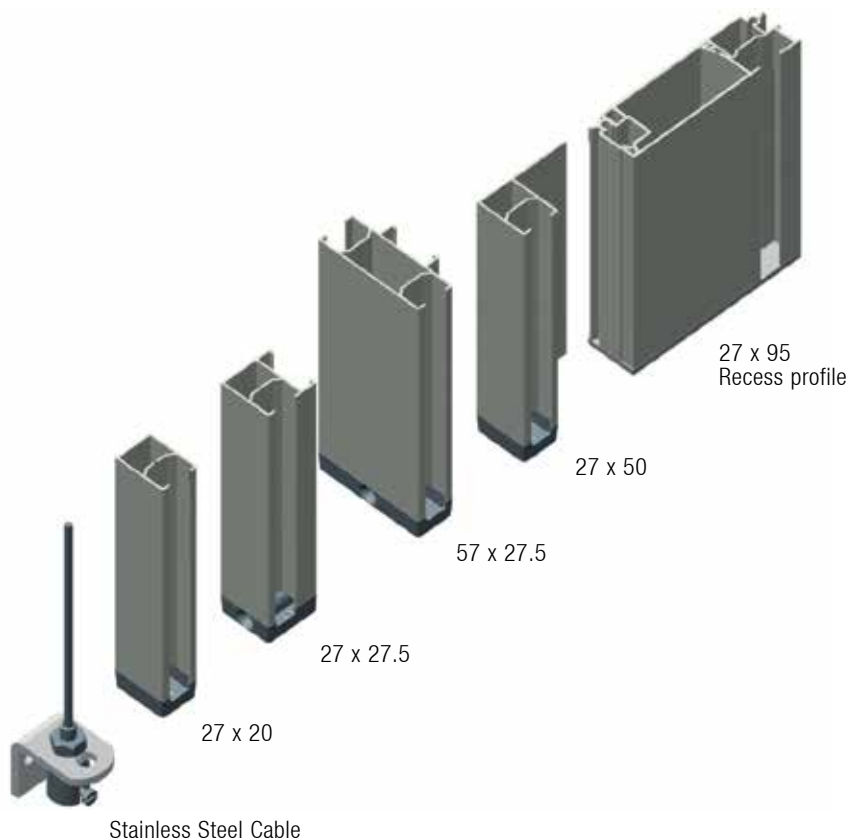

## BOTTOM RAIL SYSTEM

HunterDouglas® ProScreen offers the choice of four types of bottom rails. The 20 x 38 mm bottom rails, for use with the aluminium guides (type A), is fitted with a guide block to minimise noise from vibrations.

The bottom rail can be finished in a range of ways, specifically:

- Natural anodised
- Powder coated in the desired RAL colour
- Finished in the pocket of the HunterDouglas® glass fibre fabric (type D).

The HunterDouglas® glass fibre fabric has the same width as the bottom rail.



# ProScreen ZIP

## SYSTEMS

HunterDouglas® ProScreen Zip is made up of two systems, in two designs. The selection depends on the dimensions of the window and the desired design.

Type	Square	Chamfered	Without
85	x	x	
95	x		

Type	Aluminium guiding Max. width x height in mm
85	3000 x 2000
95	3000 x 3000



*Square head box*



*Chamfered head box*

## GUIDE SYSTEMS

HunterDouglas® ProScreen Zip provides two aluminium extruded side channels:

1. Snap on channel
2. Recess.



*Snap on channel  
38 x 27.5 mm*



*Recess side channel  
38 x 96 mm*

## BOTTOM RAIL SYSTEM

HunterDouglas® ProScreen Zip has a 20 x 38 mm aluminium bottom bar. The maximum weight of the ProScreen Zip bottom rail is 2.75 kg. in total.



*Aluminium 20 x 38 mm.*

A bottom rail can be finished natural anodised or powder coated in the desired RAL colour.



# Ultimate Screen ZIP

## SYSTEMS

HunterDouglas® Ultimate Screen Zip is available in two systems, in two designs. The selection depends on the dimensions of the window and the desired design. Dimensions increase to 3000 mm wide and 5000 mm high.

Type	Square	Chamfered	Without
100	x	x	
125	x		

Type	Aluminium guiding Max. width x height in mm
100	4000 x 2700
125	3000 x 5000



*Square head box*



*Chamfered head box*

## PATENT

Due to the weight and height, the installation of large motorised cassette blinds can already be a challenging task. In addition, the façade construction may hinder the standard installation of a box on top of pre-installed side guides. The patented construction of Ultimate Screen

ZIP Roller Blinds allows frontal click installation of the head box in the side guides. In face fix situations, the head box does not need to be installed on top of the side guides first. This keeps the side guiding profiles small and above all makes the Ultimate Screen ZIP Roller Blind very easy and safe to install by one person.



## GUIDE SYSTEMS

HunterDouglas® Ultimate Screen Zip provides an aluminium extruded snap on side channel.

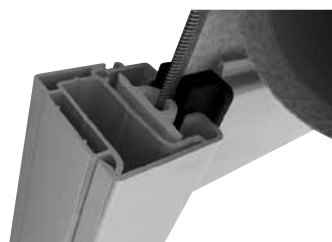

*Snap on channel 37 x 38 mm*

## BOTTOM RAIL SYSTEM

HunterDouglas® Ultimate Screen Zip consists of a 22 x 48 mm aluminium bottombar. The maximum weight of the Ultimate Screen Zip bottom rail is 3.08 kg. in total.



*Aluminium 22 x 48 mm.*

A bottom rail can be finished natural anodised or powder coated in the desired RAL colour.

# HUNTER DOUGLAS

## ARCHITECTURAL

For 50 years, Hunter Douglas has been dedicated to innovation. As the field of Sun Control grows, we pride ourselves on leading the way as pioneers in the area.

We are working alongside architects and designers throughout the globe, discovering new, inventive methods of managing heat, light and energy. We are committed to crafting products that meet the highest standards of construction and performance using the best materials available. We aim to provide you with the tools and vision that will create projects that inspire.



▲ WINDOW COVERINGS

SUN CONTROL ▼



▲ CEILINGS

FAÇADES ▼



Designed  
to work for you

© Registered trademark - a HunterDouglas® product Pats. & Pats. Pend. - Technical data subject to change without notice. © Copyright Hunter Douglas 2016. No rights can be derived from copy, text pertaining to illustrations or samples. Subject to changes in materials, parts, compositions, designs, versions, colours etc., even without notice. MX120B00



PARTICIPANT



**HunterDouglas**   
Window Coverings



### ARCHITECTURAL SERVICES

We support our business partners with a wide range of technical consulting and support services for architects, developers and installers. We assist architects and developers with recommendations regarding materials, shapes and dimensions, colours and finishes. We also help with the creation of design proposals, visualisations, and installation drawings. Our services to installers range from providing detailed installation drawings and instructions to training installers and advising on the building site.

## Learn More

- Contact our Sales office
- [www.hunterdouglasarchitectural.com](http://www.hunterdouglasarchitectural.com)



Printed on  
EU Ecolabel  
certified paper



*Hunter Douglas products and solutions are designed to improve indoor environmental quality and conserve energy, supporting built environments that are comfortable, healthy, productive, and sustainable.*



*Our paint and aluminium melting processes are considered to be one of the industry standards in terms of clean production processes. All aluminium products are 100% recyclable at the end of their lifecycle.*



Window Coverings  
Ceilings  
Sun Control  
Façades



China  
Hong Kong  
India  
Indonesia  
Japan  
Korea  
Malaysia  
Philippines  
Singapore  
Taiwan  
Thailand  
Vietnam

Australia  
Europe  
Latin America  
North America

Hunter Douglas Asia Operations  
Tel: +603 5191 2020

[www.hunterdouglas.asia](http://www.hunterdouglas.asia)



Copyright by Hunter Douglas.  
Technical data subject to change without notice.  
201006-4-1.0

©Registered trademark of Hunter Douglas