

A photograph of a modern building facade featuring external Venetian blinds. The building has a light-colored, horizontally-slatted exterior. A prominent feature is a blue balcony with a curved top. The blinds are installed on multiple levels of windows, and the building is set against a clear blue sky with some greenery visible in the foreground.

External Venetian Blinds

For many years European architects have been specifying HunterDouglas® External Venetian Blinds as experience has shown to be the most efficient and most flexible form of solar and light control.

HunterDouglas 
Window Coverings



External Venetian Blinds

Complete Flexibility

DESIGN

The design, measurements, operation and motors of the new generation External Venetian Blinds are identical to the existing blinds. However, this new generation requires no special conditions like deeper stacking, complicated installation or special electronic components. The External Venetian Blinds are available in a new project colour collection and in several dimensions of slats, up to 100 mm width.

FUNCTIONALITY & COMFORT

Tilting and raising/lowering mechanism is made of durable maintenance free PVC. The positive tilting mechanism prevents movement of the slats by wind load. A stainless steel tilting spring is enclosed in two different slat suspension rings for user friendly, smooth and exact operation.

EASY INSTALLATION

HunterDouglas External Roller Blinds can be mounted very easily. Depending on the local situation of the building, several mounting solutions are available to install the blinds to the façade.



CONTENTS	Page
Systems	2 - 3
Side guiding	4
System Properties	5
Size Limitations	6 - 7
Indoor Environmental Quality & Productivity	8
Energy & Light Tool	9

ENERGY & LIGHT

HunterDouglas® External Venetian Blinds are designed to improve indoor environmental quality and conserve energy. These systems help create built environments that are comfortable, healthy, productive, and sustainable. Our engineering and production processes minimize embodied environmental impact while meeting the highest standards for commercial, hospitality, industrial, and commercial applications. In order to obtain the optimal shading performance for a building and its occupants we developed computer simulation and calculation tools. Our project support team can analyze, visualize and optimize Window Covering Solutions with the HunterDouglas® Energy and Light Tool.

Innovative Products Make Innovative Projects



HunterDouglas 
Window Coverings

Systems

50 MM FLEXIBLE SLAT: 50F

The hardware system for tilting, lowering and raising is incorporated in the headrail.

- Operation by:
 - (K) crank with 45° or 90° feed through with cardan joint
 - (EL) motor
- Side guiding:
 - (A) stainless steel cable

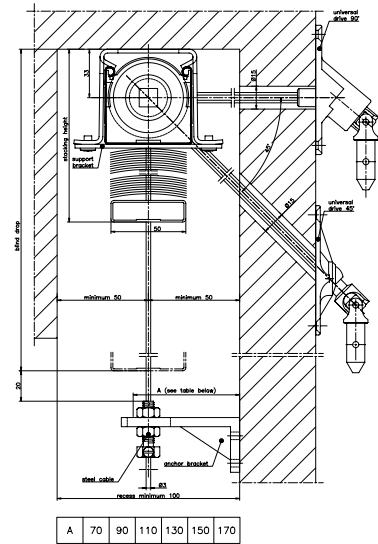
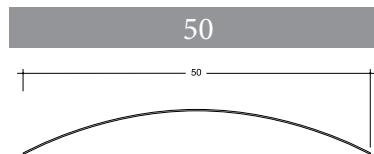
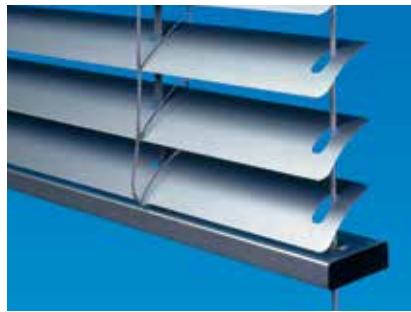

60 MM / 80 MM, WITH BEADED EDGES

The hardware system for tilting, lowering and raising is incorporated in the headrail.

- Operation by:
 - (K) crank with 45° or 90° feed through with cardan joint
 - (EL) motor
- Side guiding:
 - (A) stainless steel cable
 - (AS) standard side guiding channels
 - (ASS) push-on guiding channels
 - (ASK) guiding mounted with clamping brackets
- Optional:
 - 40° tilting angle
 - round side guiding channels with ASK
 - mounting systems on or between the side track

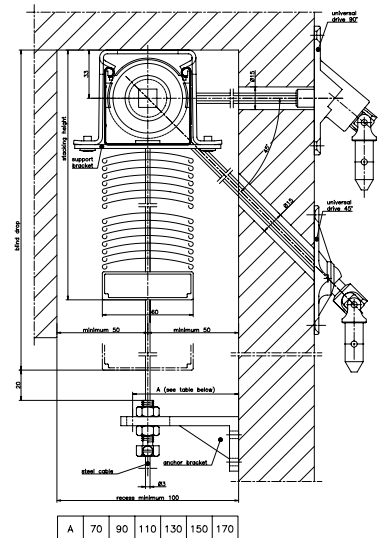
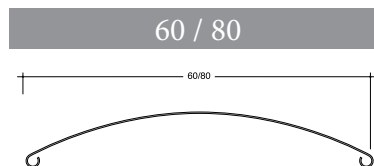

60 MM / 80 MM, FLEXIBLE SLATS: 60F & 80F

The hardware system for tilting, lowering and raising is incorporated in the headrail.

- Operation by:
 - (K) crank with 45° or 90° feed through with cardan joint
 - (EL) motor
- Side guiding:
 - (A) stainless steel cable
- Optional:
 - 40° tilting angle

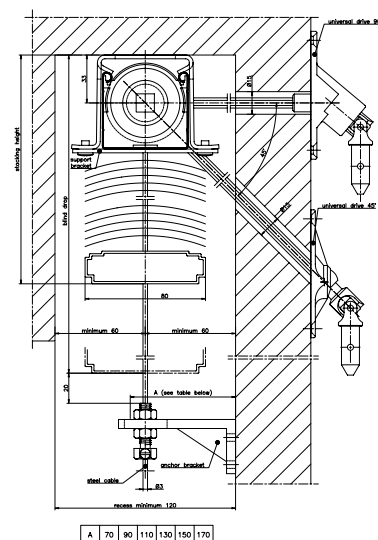
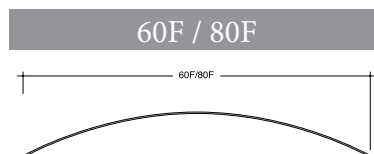

Systems

88 MM, WITH BEADED EDGES

The hardware system for tilting, lowering and raising is incorporated in the headrail. Rolled-in insert made of LDPE (plastic) for sound absorption. Slats are shape in a “Z” form, for optimal closure.

- Operation by:
 - (K) crank with 45° or 90° feed through with cardan joint
 - (EL) motor
- Side guiding:
 - (AS) standard side guiding channels
 - (ASS) push-on guiding channels
 - (ASK) guiding mounted with clamping brackets
- Optional:
 - 40° tilting angle

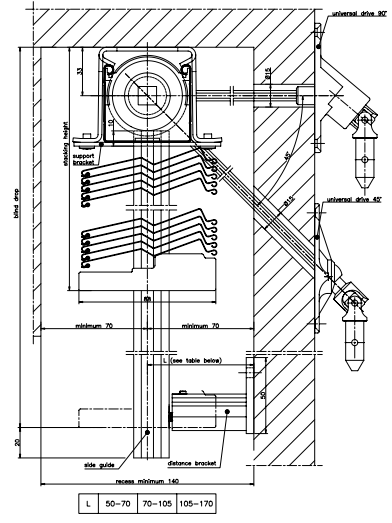
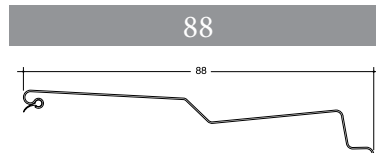

100 MM, FLEXIBLE SLATS: 100F

The hardware system for tilting, lowering and raising is incorporated in the headrail.

- Operation by:
 - (K) crank with 45° or 90° feed through with cardan joint
 - (EL) motor
- Side guiding:
 - (A) stainless steel cable
- Optional:
 - 40° tilting angle

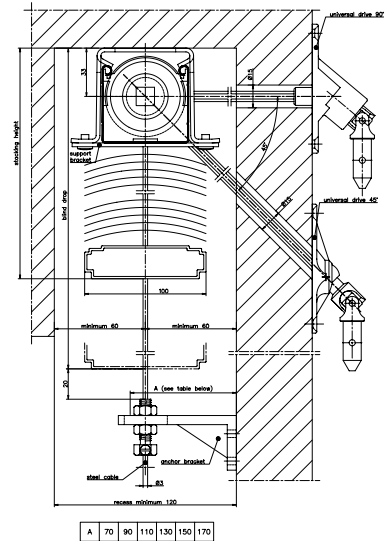
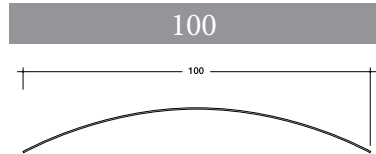

Project : The Bond
 Architect: Bovis Lend Lease
 Product : Exterior Venetian Blinds

Side Guiding

TYPE A: CABLE GUIDING

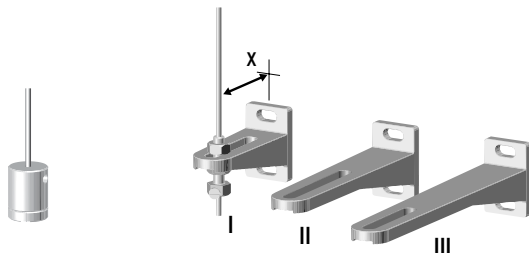

X = distance from cable to wall

	X - Min.	X - Max.
I	27	73
II	67	133
III	124	173

FLOOR MOUNT BRACKET

WALL MOUNT BRACKETS

TYPE AS: STANDARD SIDE CHANNEL GUIDING



L1 = 50 - 70 mm
L2 = 70 - 105 mm
L3 = 105 - 170 mm

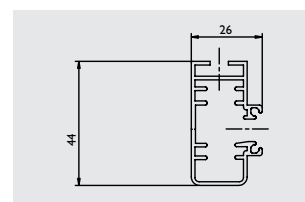
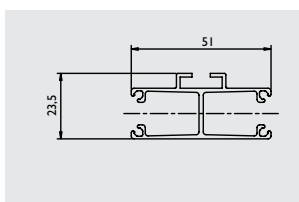
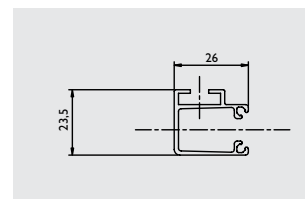
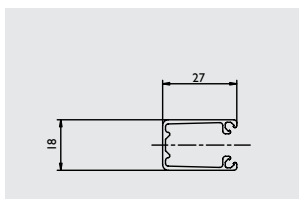
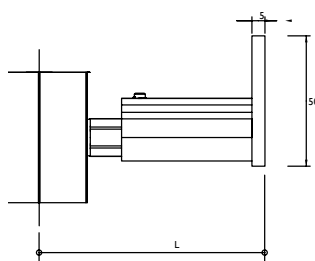

TYPE ASS: PUSH-ON GUIDING SYSTEM

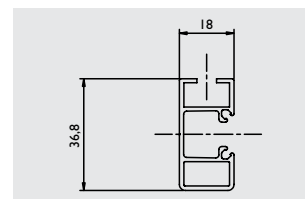
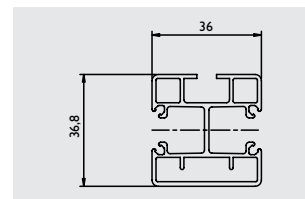
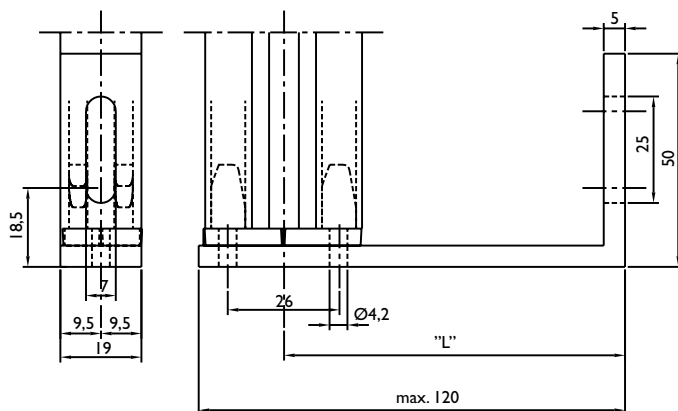

TYPE ASK: SIDE CHANNEL GUIDING WITH CLAMPING PIECE

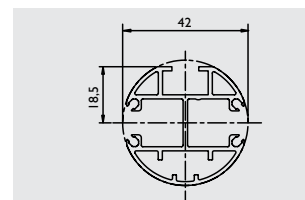
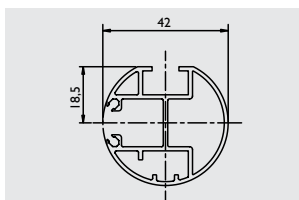
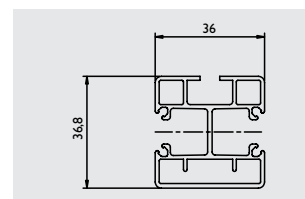
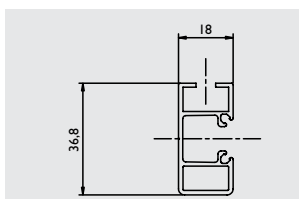
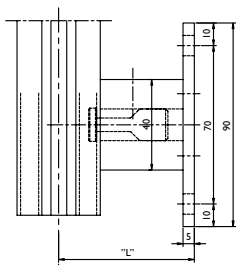

All sizes in mm

Systems Properties

TYPE OF SLATS

- 50F mm
- 60(F) mm
- 80(F) mm
- 88 mm
- 100F mm

HEADRAIL

Rollformed zinc-plated steel U-shaped channel 57 x 51mm.

Optional: Extruded aluminium profile, natural anodized with cover and end caps.

BOTTOM RAIL

Extruded aluminium profile, natural anodized or powder coated, adapted to the shape of the slats, with plastic end caps provided with guiding pins or cable guiding rivets.

SLATS

- All slats are pre-coated with Anorcoat® conversation coating system. Colour coated with stove enameled polyester paint.
- 50 / 50F mm rollformed aluminium slats, thickness 0.2 mm. Alloy AW5182, with painted edges in the length of the slats.
- 60 / 60F mm rollformed aluminium slats, thickness 0.4 mm / 0.45 mm. Alloy HD5050, with painted edges in the length of the slats.
- 80 / 80F mm rollformed aluminium slats, thickness 0.4 mm. Alloy HD5050, with painted edges in the length of the slats.
- 88 / 100F mm rollformed aluminium slats, thickness 0.45 mm / 0.4 mm. Alloy HD5050, with painted edges in the length of the slats.

SLATS SUSPENSION

- 50F, 60(F), 80(F) and 100F mm types: UV and weather resistant woven polyester ladder braid. Slats inserted between ladders.
- 88 mm types: UV and weather resistant woven polyester ball tapes. Slats individually connected to the tape by special clips in the bead of the slat (available colour grey).

TILTING AND RAISING/ LOWERING MECHANISM

Made of durable maintenance free plastic. Positive tilting mechanism prevents movement of the slats by wind load. A stainless steel tilting spring is enclosed in two different slat suspension rings for smooth and exact operation. During lowering slats are fully closed, during raising slats are fully open. The optional automatic tilting device pre-sets the slats at a 40° angle. The system is re-set automatically during lifting of the slats.

SIDE GUIDING

- 50F, 60F, 80F and 100F mm types: Stainless steel cable, Ø 3 mm with nylon jacket, tensioned between headrail and guide cable bracket.
- 60, 80 and 88 mm types: Extruded aluminium profile with plastic insert for noise reduction, natural anodized or powder coated. Slats supplied with guiding pins at the extreme ends.

STRING TAPE

String tape consists of high tenacity polyester material (colour: black).

LIFT TAPE

Made of durable UV and weather resistant pre-shrunk polyester (6 x 0.33 mm). Alternative: 88 KV-ELV types, made of durable UV and weather resistant plastic(dymetrol), 15.2 x 1.27 mm (colour: black).

CONNECTION CORD

UV and weather resistant woven polyester cord connects slat suspension to the mechanism. Provides quick release and adjustment of the slat stack.

OPERATION

- Crank operation: With crank rod via universal joint to a self braking gearbox incorporated in the headrail or located at the extreme end of the headrail.
- Electrical operation:
With electric motor (220/240V - 50 Hz) enclosed within the headrail. The motor is thermally protected against overheating and splash proof (IP54).

Blinds can be operated individually and/or linked together. They can also be integrated in a fully automated central control system, by using group controls, solar sensors, anemometers, time switches and relays. *Check the 'Hunter Douglas® Intelligent Control System' Brochure.*

Size Limitations

EXTERNAL VENETIAN BLINDS

TYPE	Width of the slats (mm)	Type of operation (lift/tilt)	Sideguiding	Construction limits						
				Single installation			Group installation			
				Width		Height Max. (cm)	Surface Max. (m ²)	Width Max. (cm)	Height Max. (cm)	Surface Max. (cm)
				Min. (cm)	Max. (cm)					
K 50 A	50	crank	cable	45	400	400	12	800	400	16
EL 50 A	50	motor	cable	51	400	400	16	800	400	20
K 60 A	60	crank	cable	45	500	450	12	1000	450	12
K 60 AF	60 flexible	crank	cable	45	500	400	12	1000	400	12
K 60 AS	60	crank	standard sideguiding channels	52	500	400	12	1000	400	12
K 60 ASS	60	crank	push-on side guiding channels	50	300	250	7	1000	250	12
K 60 ASK	60	crank	channels with clamping brackets	56	500	400	16	1000	400	20
EL 60 A	60	motor	cable	51	500	450	16	1000	450	20
EL 60 AF	60 flexible	motor	cable	51	500	400	16	1000	400	20
EL 60 AS	60	motor	standard sideguiding channels	58	500	400	16	1000	400	20
EL 60 ASS	60	motor	push-on side guiding channels	56	300	250	7	1000	250	20
EL 60 ASK	60	motor	channels with clamping brackets	56	500	400	16	1000	400	20
K 80 A*	80	crank	cable	45	500	450	12	1000	450	12
K 80 AF*	80 flexible	crank	cable	45	500	400	12	1000	400	12
K 80 AS*	80	crank	standard sideguiding channels	52	500	400	12	1000	400	12
K 80 ASS*	80	crank	push-on side guiding channels	50	300	250	7	1000	250	12
K 80 ASK*	80	crank	channels with clamping brackets	50	500	400	12	1000	400	12
EL 80 A*	80	motor	cable	51	500	450	16	1000	450	20
EL 80 AF*	80 flexible	motor	cable	51	500	400	16	1000	400	20
EL 80 AS*	80	motor	standard sideguiding channels	58	500	400	16	1000	400	20
EL 80 ASS*	80	motor	push-on side guiding channels	56	300	250	7	1000	250	20
EL 80 ASK*	80	motor	channels with clamping brackets	56	500	400	16	1000	400	20
K 88 AS*	88	crank	standard sideguiding channels	52	400	400	10	1000	400	10
K 88 ASS*	88	crank	push-on side guiding channels	50	300	250	7	1000	250	10
K 88 ASK*	88	crank	channels with clamping brackets	50	400	400	10	1000	400	10
EL 88 AS*	88	motor	standard sideguiding channels	58	400	400	12	1000	400	16
EL 88 ASS*	88	motor	push-on side guiding channels	56	300	250	7	1000	250	16
EL 88 ASK*	88	motor	channels with clamping brackets	56	400	400	12	1000	400	16
ELV 88 A-S	88	motor	lifttape inside guiding channels	62	300	350	10	-	-	-
K 100 AF	100 flexible	crank	cable	45	440	400	12	1000	400	12
EL 100 AF	100 flexible	motor	cable	45	440	400	16	1000	400	20

WIND FORCES ON THE BEAUFORT SCALE OR IN M/SEC

Beaufort Scale	Description	Average wind strength		Effects on land
		m/s	km/h	
0	Calm	0 - 2	<1	Smoke rises vertically
1	Light air	0.3 - 1.4	1 - 5	Smoke drift in the wind
2	Light breeze	1.5 - 3.4	6 - 12	Leaves rustle. Wind left on face
3	Gentle breeze	3.5 - 5.4	13 - 19	Small twigs in constant motion. Light flags extended
4	Moderate wind	5.5 - 7.4	20 - 27	Dust, leaves and loose paper raised. Small branches move
5	Fresh wind	7.5 - 10.4	28 - 37	Small tree sway
6	Strong wind	10.5 - 13.4	38 - 48	Large branches move. Whistling in phone wires. Difficult to use umbrellas
7	Very strong wind	13.5 - 17.4	49 - 62	Whole trees in motion
8	Gale	17.5 - 20.4	63- 73	Twigs break off trees. Difficult to walk
9	Sever gale	20.5 - 24.4	74 - 87	Chimney pots and slates removed
10	Storm	24.5 - 28.4	88 - 102	Trees uprooted. Structural damage.
11	Severe storm	28.5 - 32.4	103 - 117	Widespread damage
12	Hurricane force	>32.5	>118	Widespread damage. Very rarely experienced on land.

The standards for external products are specified in the European Standard EN 13659

Size Limitations

WIND LOAD LIMITS EXTERNAL VENETIAN BLINDS

Width (cm)	Rollformed with side guides		Rollformed with cable guides		Flexible with cable guides	
	(bft)	(m/s)	(bft)	(m/s)	(bft)	(m/s)
150	7	13.5 - 17.4	7	13.5 - 17.4	7	13.5 - 17.4
200	7	13.5 - 17.4	7	13.5 - 17.4	6	10.5 - 13.4
250	7	13.5 - 17.4	6	10.5 - 13.4	6	10.5 - 13.4
300	7	13.5 - 17.4	6	10.5 - 13.4	6	10.5 - 13.4
400	6	10.5 - 13.4	6	10.5 - 13.4	5	7.5 - 10.4
500	6	10.5 - 13.4	6	10.5 - 13.4	5	7.5 - 10.4

Legend:

For External Venetian Blinds the wind load limits to be used are dependent on the type of product. Once the wind load limit has been reached the blind has to be retracted.

The values listed in the table apply to a distance of ≤ 10 cm between the slat and the façades, a slat gage of ≤ 0.4 mm and a blind height of less than 240cm.

Depending on the manufacturer's recommendation, larger blinds (>200 cm) may be supplied with additional side cables. For the following cases, the values in the table are to be decreased or increased as follows:

1. For a distance between façades and slats of >10 cm to 30 cm the value of the table has to be reduced by one Beaufort. With a distance of >30 cm to 50 cm reduce the value by 2 Beaufort. For larger distance the table is not applicable.
2. For a slat gage of less than 0.4 mm reduce the value by 1 Beaufort.
3. For slats with strong profiles the value may be increased by 1 Beaufort.
4. For heights between 240 cm and 400 cm and cable guides, the value should be reduced by 1 Beaufort; for heights over 400 cm reduce the value by 2 Beauforts.



Indoor Environmental Quality & Productivity

PRODUCTIVITY

Energy saving strategies and natural resources like daylight, can create a comfortable and productive environment for occupants. Smart, sustainable design that provides good indoor environmental quality is a proven and profitable investment.

Seemingly small increases of as little as 1% in productivity could result in a much higher payback than the reduced cost of energy.

COMFORT

Comfort can be described as 'the state of mind that expresses satisfaction with the surrounding environment'.

Indoor environment quality has essentially four dimensions:

1. Thermal comfort;
2. Visual comfort;
3. Acoustic comfort;
4. Indoor air quality.

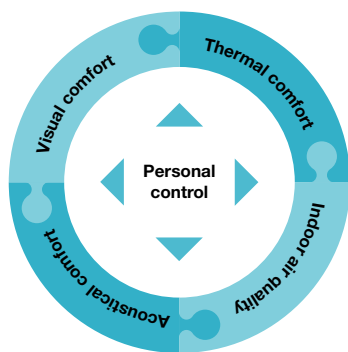

It is an accepted fact that people prefer to experience daylight through visual contact with the outside world. This is therefore, generally recognized as an important factor in influencing people's positive emotional state.

Situations that cause visual discomfort can frequently arise. The light, glare or reflection levels are just too bright and contrasts too large for optimal working conditions.

Workspaces which are comfortable, naturally lit and allow occupants to connect with outdoor space can improve productivity and reduce absenteeism. Research on the relationship between day lighting and productivity shows that the use of daylight without glare resulted in productivity gains in the order of 4%. To fully optimise the benefits of daylight, control systems can be integrated in the sun control solution.

SUSTAINABILITY & INDOOR ENVIRONMENTAL QUALITY

The environmental footprint of a building includes such factors as the use of energy, water, materials and resources. HunterDouglas® Sun Control Systems and Window Covering products can play an excellent role in reducing the environmental footprint, whilst at the same time enhancing the thermal and visual dimensions of indoor environmental quality.



Energy and Light Tool

The function of Window Coverings is to provide visual comfort and heat control. The primary function of interior window coverings is to reduce glare levels and diffusing daylight. The primary function of External window Coverings is heat control.

THERMAL COMFORT

External Window Coverings will prevent excessive solar heat gain and reduce the need for cooling in the summer. Moreover, it will also reduce - if not eliminate - the high capacity of cooling equipment needed, resulting in a reduction in the initial investment cost.

In colder climates, External Window Coverings will enable the use of solar energy to help heat the building in winter. This is often overlooked when solar control glass is selected for heat control.

Thermal comfort at a minimal environmental impact calls for a careful matching of glazing, Sun Control and HVAC equipment.

The Hunter Douglas Energy Tool helps finding an optimum solution by quantifying the effects of various External Window Coverings. The pay-off will be reduced energy costs and often reduced investment cost. On top of that: greenhouse gas emissions during the operation phase of the building will be reduced.

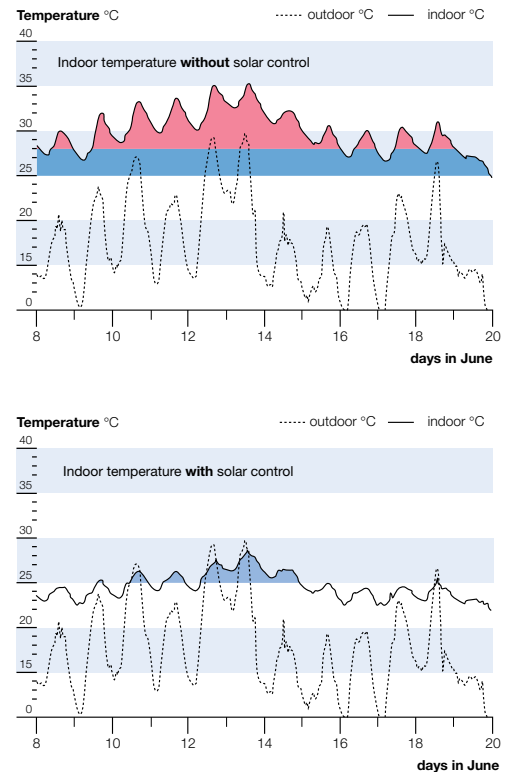

VISUAL COMFORT

Interior Window Coverings enable the use of free renewable daylight to the maximum extent, so significantly reducing the need for artificial lighting and avoiding the associated cooling loads.

The accepted factor in creating visual comfort states that the contrast within the field of view should not exceed a factor of 10. The contrast between the central visual task and its direct surroundings should not exceed a factor of 3.

When designing an office space, questions often arise around what measures should be considered to guarantee the right level of visual comfort?

The Hunter Douglas Light Tool makes the assessment of visual comfort tangible by calculating luminance levels for a model office with and without window coverings. The amount and type of glass, the orientation of the façade, the geographical location, weather, season and time of day are all taken into account before recommendations are made.

The Light Tool helps clients assess which window covering provides the aesthetic and performance levels needed to create visual comfort for their particular project.

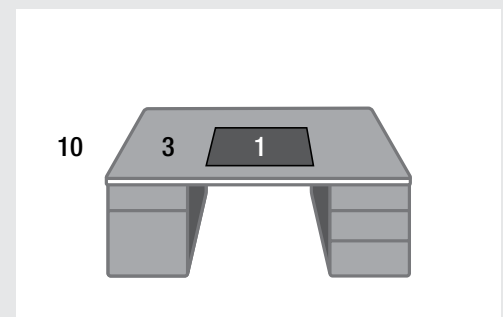
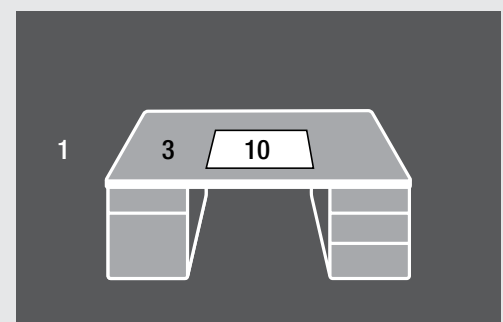

Contrast factor 1:3:10

Light Tool calculations are based on Radiance (Lawrence Berkeley Laboratories). The scene model consists of approximately 20,000 polygons. Colours and reflection values were measured in an actual model office.



HUNTER DOUGLAS

ARCHITECTURAL

For 50 years, Hunter Douglas has been dedicated to innovation. As the field of Sun Control grows, we pride ourselves on leading the way as pioneers in the area.

We are working alongside architects and designers throughout the globe, discovering new, inventive methods of managing heat, light and energy. We are committed to crafting products that meet the highest standards of construction and performance using the best materials available. We aim to provide you with the tools and vision that will create projects that inspire.

**Innovative Products
Make Innovative Projects**



Promoting sustainable
forest management
www.pefc.org

© Registered trademark - a Hunter Douglas® Products Pats. & Pats. Pend. - Technical data subject to change without notice.
© Copyright Hunter Douglas 2009. No rights can be derived from copy, text pertaining to illustrations or samples. Subject to
changes in materials, parts, compositions, designs, versions, colours etc, even without notice. **MX 911W00**



ARCHITECTURAL SERVICES

We support our business partners with a wide range of technical consulting and support services for architects, developers and installer. We assist architects and developers with recommendations regarding materials, shapes and dimensions, colours and finishes. We also help creating design proposals, visualisations and mounting drawings. Our services to installers range from providing detailed installation drawings and instructions to training installers and advising on the building site.



Printed on
EU Ecolabel
certified paper



Hunter Douglas products and solutions are designed to improve indoor environmental quality and conserve energy, supporting built environments that are comfortable, healthy, productive, and sustainable.



Our paint and aluminium melting processes are considered to be one of the industry standards in terms of clean production processes. All aluminium products are 100% recyclable at the end of their lifecycle.

Window Coverings
Ceilings
Sun Control
Façades



China
Hong Kong
India
Indonesia
Japan
Korea
Malaysia
Philippines
Singapore
Taiwan
Thailand
Vietnam

Australia
Europe
Latin America
North America

Hunter Douglas Asia Operations
Tel: +603 5191 2020

www.hunterdouglas.asia



Copyright by Hunter Douglas.
Technical data subject to change without notice.
201006-4-1.0

®Registered trademark of Hunter Douglas